



WARD MANUFACTURING

BRASS NIPPLE | *PRICE SHEET*

PRICE SCHEDULE #620715

EFFECTIVE: AUGUST 3, 2015

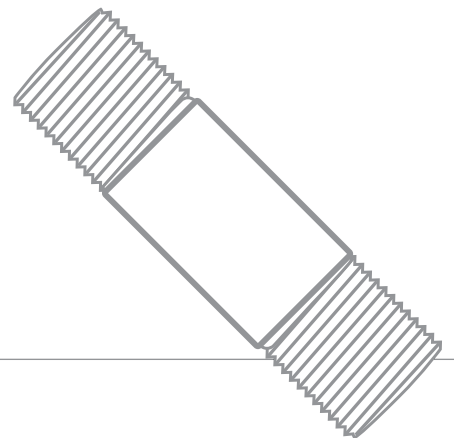

WARD!MFG

117 Gulick Street, Blossburg, PA 16912 | www.wardmfg.com | (800) 248-1027

BRASS NIPPLES

PIPE SIZE	CLOSE LGTH	CLOSE	1-1/2"	2"	2-1/2"	3"	3-1/2"	4"	4-1/2"	5"	5-1/2"	6"	7"	8"	9"	10"	11"	12"
1/8"	3/4"	16.37	18.46	19.85	22.47	24.28	26.22	29.47	33.32	36.07	38.95	41.75	49.64	54.67	67.25	73.59	79.81	84.95
1/4"	7/8"	19.14	22.14	25.06	27.16	31.87	34.69	40.77	44.25	48.25	52.29	58.81	67.07	73.47	81.65	89.67	97.86	105.89
3/8"	1"	19.83	23.47	28.52	30.91	37.79	40.77	48.53	51.67	56.67	61.60	66.63	80.91	90.69	107.31	108.07	117.96	127.94
1/2"	1-1/8"	26.45	30.62	35.96	42.78	50.21	57.32	65.66	71.26	78.53	86.24	95.61	110.78	124.12	137.72	152.33	166.65	181.23
3/4"	1-3/8"	38.12	40.63	48.01	55.66	64.21	72.06	83.76	91.11	100.56	109.88	122.34	143.37	161.44	178.79	197.04	215.02	234.46
1"	1-1/2"	56.20		69.34	80.91	93.16	107.85	121.31	135.28	149.60	163.85	178.63	208.65	238.21	265.80	294.81	318.08	351.59
1-1/4"	1-5/8"	84.81		96.85	109.54	129.62	151.67	170.72	189.04	208.47	228.04	249.06	293.82	332.85	394.72	411.61	471.18	492.34
1-1/2"	1-3/4"	110.27		118.65	142.15	163.36	187.58	212.79	239.11	264.55	289.44	314.37	367.43	417.38	467.26	517.13	567.07	616.87
2"	2"	167.91			181.33	209.25	240.87	273.76	305.20	338.42	371.21	404.17	472.75	539.12	601.17	667.72	721.51	796.38
2-1/2"	2-1/2"	443.26				463.38	525.02	583.63	626.14	688.80	741.81	812.21	925.27	1062.65	1179.51	1303.32	1404.36	1540.76
3"	2-5/8"	602.74				626.32	708.54	798.04	877.25	965.23	1048.79	1140.04	1330.25	1515.51	1659.57	1841.04	2002.07	2205.20
3-1/2"	2-3/4"																	
4"	2-7/8"	906.82				921.05	1034.19	1179.43	1273.94	1407.05	1500.42	1656.74	1901.95	2157.46	2412.81	2668.20	2924.08	3148.17

PACKAGING SCHEDULE

Pipe Size	Length	Quantity
1/8 - 1"	Close - 6"	25 Per Box
1-1/4 - 2"	Close - 6"	10 Per Box
All Other Sizes Bulk Packaging		

Distributed by:

TERMS AND CONDITIONS OF SALE:

- 1. PRICES:** This price sheet supersedes all previous issues. Prices in price sheets are subject to change without notice. Prices apply only to standard sizes as listed in catalog.
- 2. APPROVAL & ACCEPTANCE OF ORDERS:** All orders are accepted on the basis of prices in effect at the time of shipment.
- 3. TAXES:** Any Manufacturer or Sales Tax payable on the transaction under any effective statute will be added to the prices and terms quoted, unless a valid exemption certificate is on file.
- 4. CREDIT TERMS:** Two percent cash discount tenth prox., - Net 30 days. Unless otherwise stated.
- 5. DELIVERY & SHIPMENT OF GOODS:** All goods are shipped at buyer's risk. Shipments should be carefully examined upon delivery and before the carrier's delivery receipt is signed. If any loss or damage is evident, the buyer should make an appropriate notation on the delivery receipt and insist that the carrier's driver initial such exception. The contents of all packages should be carefully examined for concealed damage as soon as possible after delivery, so that the carrier can be requested, within 48 hours after delivery, to arrange for prompt inspection of the damaged goods. Completion of all orders accepted and fulfillment of all agreements or contracts entered into are subject to any delay which might be occasioned by labor disputes, fires, accidents, embargoes, trade restrictions, governmental directives or other causes beyond our control. All promises of shipment will be as closely estimated as possible. We use our efforts in every case to ship within the time promised, but cannot guarantee to do so. All claims for shortage must be made on receipt of goods. We prove our count by weighing the package. Claims for shortage are subject to that test. Typographical, clerical, arithmetical errors or omissions in orders, invoices, quotations, price schedules, acknowledgments, or other documents are subject to correction.
- 6. RETURN OF GOODS:** No goods will be taken back and credited without prior approval and issuance of a return goods authorization (RGA) number. All fittings returned with our permission must be goods sold by Ward Manufacturing, LLC, and in clean saleable condition. Credit will only be allowed on the basis of prices agreed upon. If product returned is a result of a customer ordering error or overstocking situation, the credit will be less 20 percent to cover handling costs, less any costs of returning to a saleable condition, and less transportation charges on original and return shipments. Orders for special goods are not subject to cancellation for any reason after work has been started on them, except upon agreement to make payment for all work which has been performed.
- 7. WARRANTY:** Seller warrants the material to be free of defects in material and workmanship, under normal use, proper maintenance and proper operation, for a period of one year from date of delivery to a common carrier for shipment to buyer or his designated agent. The obligation of the seller is limited to (1) repair of the material, or (2) replacement of any component or components proven defective in material or workmanship, or (3) refund of the purchase price. Seller shall have no liability for the cost of removal or reinstallation with respect to any replaced or repaired product. The election of said remedies shall be determined by seller in its sole discretion and shall be considered final disposition. All implied warranties, including the implied warranties of merchantability and fitness for a particular purpose, are hereby disclaimed and excluded. This warranty is in lieu of all other warranties, guarantees, agreements and similar obligations of seller; in no event shall seller be liable for consequential or incidental damages.
- 8. FREIGHT TERM:** Shipments of 1,000 pounds or more will be prepaid in the continental U.S. (except Alaska). We reserve the right to choose shipping point and carrier.
- 9. CARTON & BOX QUANTITY ADJUSTMENT:** On orders received for less than master carton or box quantities, we reserve the right to adjust to the next carton or box quantity above the number of pieces shown on the order. Items subject to adjustment are identified with stars in the price sheet.
- 10. WEIGHTS:** The weights per piece or per 100 pieces given in the price sheet, catalogs, and quotations are not guaranteed, but are approximate and for your convenience.
- 12. SPECIAL CONDITIONS:** Any additional cost incurred in packaging or in making any special tests or inspection requested by Buyer in addition to those commercially supplied by Ward Manufacturing, LLC., will be charged to Buyer. Such tests and inspections will be made at the factory before date of shipment. Orders for fittings or parts will be subject to a net minimum invoice charge of \$50.00 Net plus applicable handling and freight charges.
- 13. US EXPORT COMPLIANCE:** The products sold by Ward Manufacturing, LLC. may be subject to the export control laws and regulations of the United States Government. Buyer may not make any disposition of such products, by way of sale, export, re-export, transshipment or otherwise, except as permitted under applicable U.S. law.